

## Solalighting Ltd

23 Osier Way  
Olney Office Park  
Olney  
Buckinghamshire MK46 5FP  
Tel: 01234 241466 Fax: 01234 241766  
e-mail: daylight@solatube.co.uk  
website: www.solatube.co.uk



Agrément Certificate  
**08/4597**  
Product Sheet 1

### SOLATUBE TUBULAR DAYLIGHTING SYSTEMS

### SOLATUBE 160DS AND 290DS DAYLIGHTING SYSTEMS

This Agrément Certificate Product Sheet<sup>(1)</sup> relates to Solatube 160DS and 290DS Daylighting Systems, for use on roofs in new and existing, domestic and non-domestic buildings, to provide natural light inside the buildings.

(1) Hereinafter referred to as 'Certificate'.

#### CERTIFICATION INCLUDES:

- factors relating to compliance with Building Regulations where applicable
- factors relating to additional non-regulatory information where applicable
- independently verified technical specification
- assessment criteria and technical investigations
- design considerations
- installation guidance
- regular surveillance of production
- formal three-yearly review.

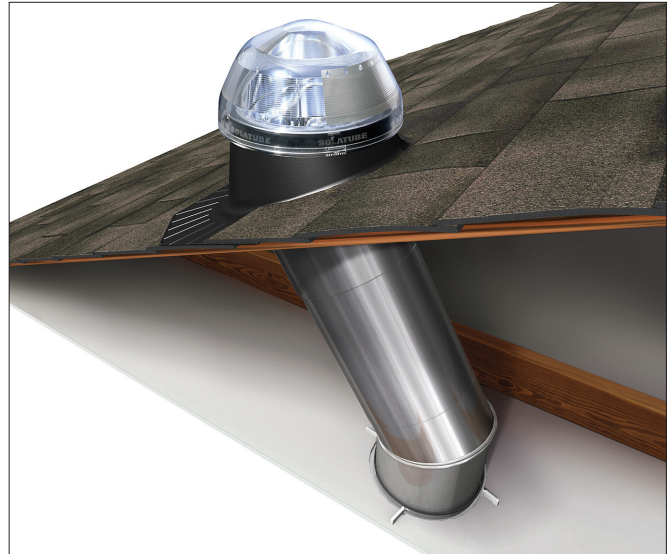

#### KEY FACTORS ASSESSED

**Light transmittance** — the systems will transmit natural light through the attic space into a ceiling below (see section 6).

**Strength and stability** — the systems have adequate resistance to wind and snow loads likely to be encountered in service (see section 7).

**Weathertightness** — the systems will provide satisfactory resistance to moisture ingress (see section 8).

**Behaviour in relation to fire** — the polycarbonate dome is classified as Tp(a) rigid and the polycarbonate diffuser as Tp(b) rigid or semi-rigid in accordance with national Building Regulations. The aluminium and aluminium coated steel flashing materials are non-combustible (see section 9).

**Thermal properties** — the systems can achieve U values  $2.2 \text{ W}\cdot\text{m}^{-2}\cdot\text{K}^{-1}$  or better (see section 10).

**Condensation risk** — the risk of condensation on the product's internal surface will depend on the building type (see section 11).

**Durability** — the systems will have a life of at least 10 years (see section 14).

The BBA has awarded this Certificate to the company named above for the systems described herein. These systems have been assessed by the BBA as being fit for their intended use provided they are installed, used and maintained as set out in this Certificate.

On behalf of the British Board of Agrément

A handwritten signature in black ink, appearing to read 'John Albon'.

A handwritten signature in black ink, appearing to read 'Claire Curtis-Thomas'.

Date of Second issue: 20 October 2015

John Albon — Head of Approvals

Claire Curtis-Thomas

Originally certificated on 22 December 2008

Construction Products

Chief Executive

*The BBA is a UKAS accredited certification body — Number 113. The schedule of the current scope of accreditation for product certification is available in pdf format via the UKAS link on the BBA website at [www.bbacerts.co.uk](http://www.bbacerts.co.uk)*

*Readers are advised to check the validity and latest issue number of this Agrément Certificate by either referring to the BBA website or contacting the BBA direct.*

British Board of Agrément  
Bucknalls Lane  
Watford  
Herts WD25 9BA

©2015

tel: 01923 665300  
fax: 01923 665301  
[clientservices@bba.star.co.uk](mailto:clientservices@bba.star.co.uk)  
[www.bbacerts.co.uk](http://www.bbacerts.co.uk)

# Regulations

In the opinion of the BBA, Solatube 160DS and 290DS Daylighting Systems, if installed, used and maintained in accordance with this Certificate, can satisfy or contribute to satisfying the relevant requirements of the following Building Regulations (the presence of a UK map indicates that the subject is related to the Building Regulations in the region or regions of the UK depicted):



## The Building Regulations 2010 (England and Wales) (as amended)

<b>Requirement:</b> A1	<b>Loading</b>
Comment:	The systems will have sufficient strength and stiffness to sustain the design load. See sections 7.1 and 7.2 of this Certificate.
<b>Requirement:</b> B2(1)	<b>Internal fire spread (linings)</b>
Comment:	The diffuser can be classified as Tp(b) material and can contribute to satisfying this Requirement. See section 9.1 of this Certificate.
<b>Requirement:</b> B4(2)	<b>External fire spread</b>
Comment:	The dome can be classified as Tp(a) rigid material and can contribute to satisfying this Requirement. See section 9 of this Certificate.
<b>Requirement:</b> C2(b)	<b>Resistance to moisture</b>
Comment:	The systems will not adversely affect the resistance of the roof to the passage of moisture. The systems provide adequate resistance to the ingress of precipitation. See section 8 of this Certificate.
<b>Requirement:</b> C2(c)	<b>Resistance to moisture</b>
Comment:	The risk of surface condensation on the systems will depend on the building humidity class. See sections 11.1, 11.2 and 11.4 of this Certificate.
<b>Requirement:</b> K5.4	<b>Safe access for cleaning windows etc (applicable to England only)</b>
Comment:	Provisions must be made regarding the safe cleaning of the skylights. See sections 12.1 and 12.2 of this Certificate.
<b>Requirement:</b> L1(a)(i)	<b>Conservation of fuel and power</b>
Comment:	The systems can contribute to satisfying this Requirement. See section 10 of this Certificate. The systems can also contribute to daylighting. See sections 6.1 and 6.2 of this Certificate.
<b>Requirement:</b> N4	<b>Safe access for cleaning windows etc (applicable to Wales only)</b>
Comment:	Provisions must be made regarding the safe cleaning of the skylights. See sections 12.1 and 12.2 of this Certificate.
<b>Regulation:</b> 7	<b>Materials and workmanship</b>
Comment:	The systems are acceptable when used in accordance with this Certificate. See sections 14.1 and 14.3 and the <i>Installation</i> part of this Certificate.
<b>Regulation:</b> 26	<b>CO<sub>2</sub> emission rates for new buildings</b>
<b>Regulation:</b> 26A	<b>Fabric energy efficiency rates for new dwellings (applicable to England only)</b>
<b>Regulation:</b> 26A	<b>Primary energy consumption rates for new buildings (applicable to Wales only)</b>
<b>Regulation:</b> 26B	<b>Fabric performance values for new dwellings (applicable to Wales only)</b>
Comment:	The systems can contribute to satisfying these Regulations when appropriate compensatory fabric/services measures are taken. See section 10 of this Certificate.



## The Building (Scotland) Regulations 2004 (as amended)

<b>Regulation:</b> 8(1)(2)	<b>Durability, workmanship and fitness of materials</b>
Comment:	The systems can contribute to a construction satisfying this Regulation. See sections 13.1, 13.2, 14.1 and 14.3 and the <i>Installation</i> part of this Certificate.
<b>Regulation:</b> 9	<b>Building standards applicable to construction</b>
<b>Standard:</b> 1.1(a)(b)	<b>Structure</b>
Comment:	The systems will have sufficient strength and stiffness to sustain design loads with reference to clause 1.1.2 <sup>(1)(2)</sup> . See sections 7.1 and 7.2 of this Certificate.
<b>Standard:</b> 2.5	<b>Internal linings</b>
Comment:	The diffuser can be classified as Tp(b) semi-rigid material and can be used in accordance with the area and separation distances required by clauses 2.5.6 <sup>(1)(2)</sup> and 2.5.7 <sup>(1)(2)</sup> . See section 9.1 of this Certificate.
<b>Standard:</b> 2.8	<b>Spread from neighbouring buildings</b>
Comment:	The external dome is classified as having low vulnerability and is subject to limitations with respect to proximity to boundaries in accordance with clause 2.8.1 <sup>(1)(2)</sup> and 2.5.6 <sup>(1)(2)</sup> . See section 9 of this Certificate.
<b>Standard:</b> 3.10	<b>Precipitation</b>
Comment:	The systems provide adequate resistance to the ingress of precipitation, with reference to clause 3.10.1 <sup>(1)(2)</sup> . See section 8 of this Certificate.
<b>Standard:</b> 3.15	<b>Condensation</b>
Comment:	The risk of surface condensation on the systems will depend on the humidity class of the building, with reference to clauses 3.15.1 <sup>(1)</sup> and 3.15.4 <sup>(1)</sup> . See sections 11.1, 11.2 and 11.4 of this Certificate.
<b>Standard:</b> 3.16	<b>Natural lighting</b>
Comment:	The systems can contribute to providing natural light to a building, with reference to clauses 3.16.1 <sup>(1)</sup> and 3.16.3 <sup>(1)</sup> . See sections 6.1 and 6.2 of this Certificate.

Standard:	4.8(c)	Danger from accidents
Comment:		The provisions described in clause 4.8.3 <sup>(1) (2)</sup> of this Standard regarding the safe cleaning of the skylights, must be taken into account. See sections 12.1 and 12.2 of this Certificate.
Standard:	6.1(b)	Carbon dioxide emissions
Comment:		The systems can contribute to satisfying this Standard when appropriate compensatory fabric/services measures are taken. See section 10 of this Certificate.
Standard:	6.2	Building insulation envelope
Comment:		The systems can contribute to satisfying this Standard. See section 10 of this Certificate.
Standard:	7.1(a)(b)	Statement of sustainability
Comment:		The systems can contribute to satisfying the relevant requirements of Regulation 9, Standards 1 to 6, and therefore will contribute to a construction meeting a bronze level of sustainability as defined in this Standard.
Regulation:	12	<b>Building standards applicable to conversions</b>
Comment:		All comments given for these systems under Regulation 9, Standards 1 to 6, also apply to this Regulation, with reference to clause 0.12.1 <sup>(1) (2)</sup> and Schedule 6 <sup>(1) (2)</sup> . (1) Technical Handbook (Domestic). (2) Technical Handbook (Non-Domestic).



## The Building Regulations (Northern Ireland) 2012 (as amended)

Regulation:	23	<b>Fitness of materials and workmanship</b>
Comment:		The systems are acceptable. See sections 14.1 and 14.3 and the <i>Installation</i> part of this Certificate.
Regulation:	28(b)	<b>Resistance to moisture and weather</b>
Comment:		The systems will not adversely affect the resistance of the roof to the passage of moisture. See section 8 of this Certificate.
Regulation:	30	<b>Stability</b>
Comment:		The systems have sufficient strength and stiffness to sustain the design loads. See sections 7.1 and 7.2 of this Certificate.
Regulation:	34	<b>Internal fire spread – Linings</b>
Comment:		The diffuser can be classified as Tp(b) material. See section 9.1 of this Certificate.
Regulation:	36(b)	<b>External fire spread</b>
Comment:		The dome can be classified as Tp(a) rigid material. See section 9 of this Certificate.
Regulation:	39(a)(b)	<b>Conservation measures</b>
Comment:		The systems can contribute to satisfying this Regulation. See section 10 of this Certificate. The systems can also contribute to daylighting. See sections 6.1 and 6.2 of this Certificate.
Regulation:	40(2)	<b>Target carbon dioxide emissions rate</b>
Comment:		The systems can contribute to satisfying this Regulation when appropriate compensatory fabric/services measures are taken. See section 10 of this Certificate.
Regulation:	99	<b>Safe access for cleaning glazing</b>
Comment:		Provisions must be made regarding the safe cleaning of rooflights. See sections 12.1 and 12.2 of this Certificate.

### Construction (Design and Management) Regulations 2015

### Construction (Design and Management) Regulations (Northern Ireland) 2007

Information in this Certificate may assist the client, Principal Designer/CDM co-ordinator, designer and contractors to address their obligations under these Regulations.

See sections: 4 Use (4.4) and 12 Safety (12.1 and 12.2) of this Certificate.

## Additional Information

### NHBC Standards 2014

NHBC accepts the use of Solatube 160DS and 290DS Daylighting Systems, provided they are installed, used and maintained in accordance with this Certificate, in relation to *NHBC Standards*, Chapters 7.1, *Flat roofs and balconies* and 7.2, *Pitched roofs*.

## Technical Specification

### 1 Description

1.1 Solatube 160DS and 290DS Daylighting Systems are available as a kit of parts to assemble into a roof-to-ceiling light tube (see Figure 1). The components comprise:

- dome — transparent injection-moulded polycarbonate greater than 3 mm thick, with the ultraviolet (UV) stabiliser mixed into the polycarbonate material at the moulding stage. 160DS (250 mm) and 290DS (350 mm) models have Raybender<sup>(1)</sup> 3000 dome technology — a series of Fresnel lenses that refract low-level light into the tube section. Both models feature LightTracker<sup>(2)</sup> dome technology — a reflector unit positioned at the back of the dome to reflect in more low-level light into the system

- roof flashing 160DS and 290DS — to suit specific roof type
  - flat roofs (metal, membrane, bituminous) — powder-coated galvanized steel
  - slate and plain tile roofs (metal, membrane, bituminous) — powder-coated galvanized steel/aluminium
- top tube assembly 160DS and 290DS
  - reflective 300 mm long aluminium tubing with Spectralight<sup>(1)</sup> Infinity laminated coating, incorporating 0° to 30° adjustable angle that twists to the required angle in order to accommodate different roof pitches and route tubing around obstacles in the attic space. The top of the tube has a polycarbonate dome ring with snap fit fixings to accommodate the roof dome
- extension tubes 160DS and 290DS
  - straight tube lengths: reflective 610 mm long aluminium tubing with Spectralight Infinity laminated coating incorporating locating slots for parallel or tapered assembly
  - angled tube lengths: 580 mm long aluminium tubing with Spectralight Infinity laminated coating, incorporating three variable joints (0° to 30°) which can be arranged to provide a variety of angles and configurations
- bottom tube assembly 160DS and 290DS
  - reflective 305 mm long aluminium tubing with Spectralight Infinity laminated coating, incorporating an adjustable angle (0° to 30°). The base of the unit is fitted with a white acrylic ceiling ring with an integral twist-lock ceiling-fixing mechanism
- diffuser 160DS and 290DS
  - Optiview<sup>(1)</sup> — injection-moulded, acrylic dress ring and double-glazed polycarbonate Fresnel lens diffuser
- self-adhesive foam strip
  - Solafoam<sup>(1)</sup> — polyether, polyurethane foam
- fixings 160DS and 290DS (250 mm and 350 mm)
  - dome screws
  - flashing screws
  - flashing fixings (as appropriate to type)
  - drywall mounting screws
  - tube screws
  - expansion joint seal — self-adhesive nylon brush seal
  - aluminium joint-sealing tape
  - flashing sealant as required.

(1) Registered trademark.

(2) Trademark.

1.2 The systems are available in two sizes (see Table 1).

<i>Table 1 Sizes</i>	
Product code	Tube diameter (mm)
160DS	250
290DS	350

Figure 1 Semi-exploded view of Solatube 160DS and 290DS Daylight Systems

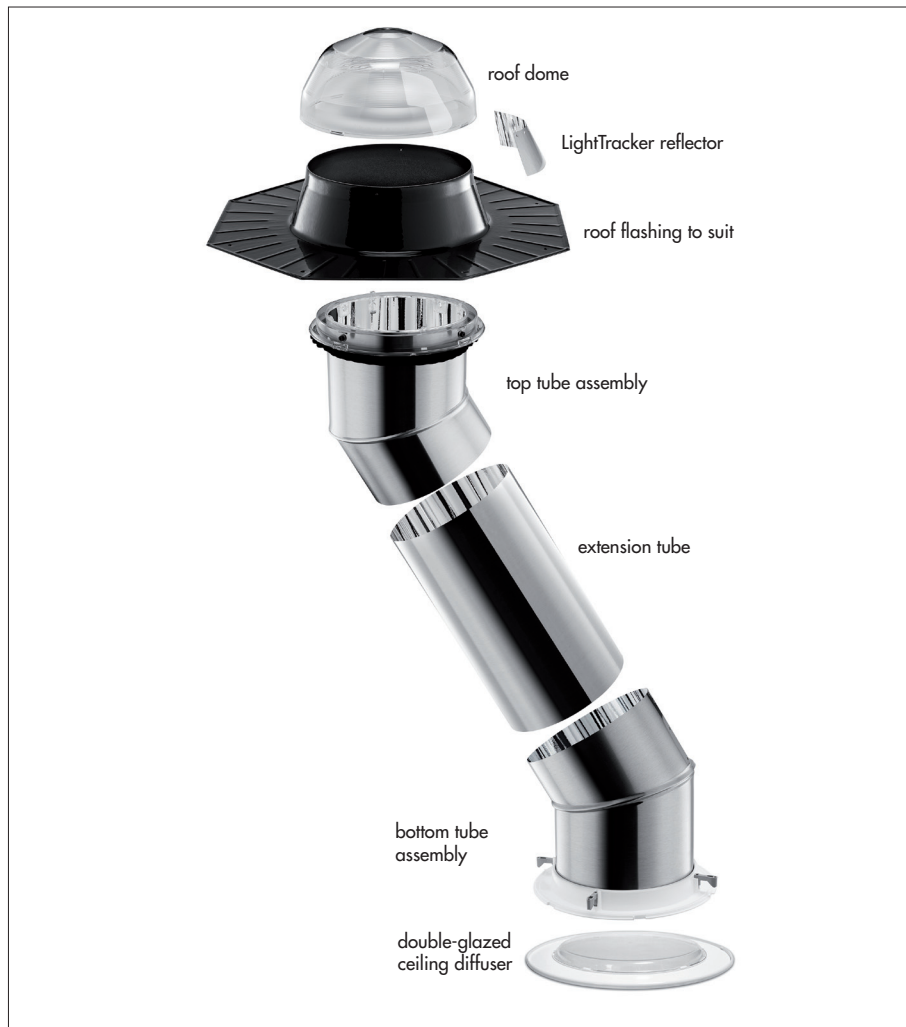

## 2 Manufacture

2.1 Polycarbonate sheets are injection moulded to the appropriate size. Flashings are fabricated from aluminium or galvanized steel, and powder coated. The reflecting material is laminated to aluminium.

2.2 As part of the assessment and ongoing surveillance of product quality, the BBA has:

- agreed with the manufacturer the quality control procedures and product testing to be undertaken
- assessed and agreed the quality control operated over batches of incoming materials
- monitored the production process and verified that it is in accordance with the documented process
- evaluated the process for management of nonconformities
- checked that equipment has been properly tested and calibrated
- undertaken to carry out the above measures on a regular basis through a surveillance process, to verify that the specifications and quality control operated by the manufacturer are being maintained.

## 3 Delivery and site handling

The systems are delivered to site in kit form, wrapped in bubble-wrap protective sheet and boxed ready for installation. Each box carries a sticker bearing the customer's name, details, order number, installation instructions and delivery documentation.

## Assessment and Technical Investigations

The following is a summary of the assessment and technical investigations carried out on Solatube 160DS and 290DS Daylighting Systems.

## 4 Use

4.1 Solatube 160DS and 290DS Daylighting Systems are satisfactory for use on pitched and flat roofs of new and existing, domestic or non-domestic buildings. New roofs should be designed in accordance with the relevant national Building Regulations.

4.2 Two variations of pitched roof flashings are available, to allow for installation with tiles or slates. In addition to these, separate roof flashings are available for flat felt roofs (see Figure 2).

Figure 2 Roof style configurations



4.3 The systems are suitable for flat or pitched (with pitches between 15° and 65°), tiled or flat roofs. Other custom-designed flashings are available from the Certificate holder for pitches of 66° to 90°, but these are outside the scope of this Certificate.

4.4 Cutting of structural members of the roof should be avoided if possible, but where this is necessary, it is important that the roof is checked by a suitably-qualified and experienced individual to ensure that it can carry the additional loads the installation may impose, strengthening the roof if necessary.

4.5 The reflecting light tubes are designed to extend through the roof space into the diffuser in the ceiling below. Tubes in the top roof assembly and the bottom assembly are designed with an angle converter, which is a rotating section set at an offset in the tube to allow for any angle of tubing through the roof space. Straight extension tubes are available for deeper roof spaces. To maximise light transmittance, arrangements should be as simple as possible.

## 5 Practicability of installation

The systems are designed to be installed by a competent general builder, or a contractor, experienced with these types of systems.

## 6 Light transmittance

6.1 For design purposes, the approximate light transmittance characteristics at normal incidence are given in Table 2 of this Certificate.

Table 2 Light transmittance

Material	Light transmittance <sup>(1)</sup> (%)	Haze (%)
Clear dome (with Raybender lenses 250 mm or 350 mm)	95	86
Flush Optiview diffuser	90	94 <sup>(2)</sup>

(1) In accordance with ASTM D 1003 : 2000.

(2) Results are due to the prismatic nature of the diffuser.

6.2 For design purposes the loss in light owing to changes in angles of the light tubes is shown in Table 3 of this Certificate.

Table 3 Loss in light owing to changes in angle (250 mm skylight)

Angle of tube <sup>(1)</sup> (±5°)	% Light transmittance (±5°)
180	100
152	62
123	53
Staggered as in Certificate holder's installation guide	55

(1) See Figure 3 of this Certificate.

Figure 3 Illustration of various light angles tested

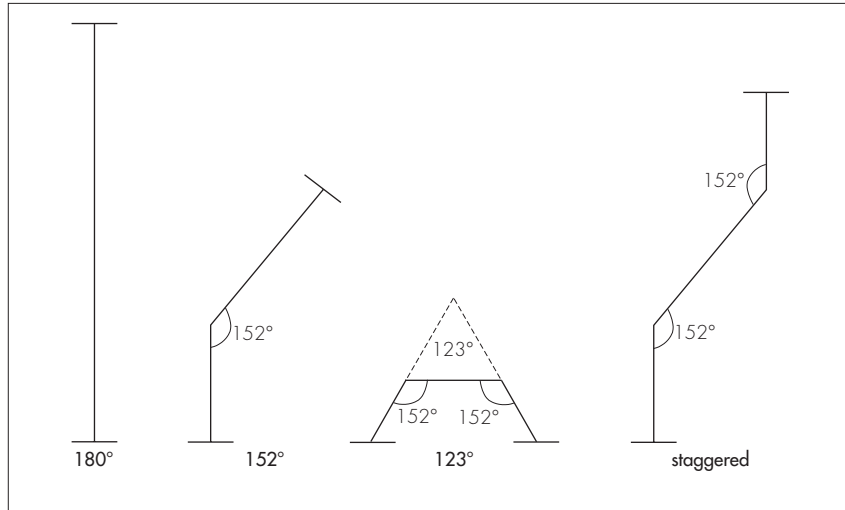

6.3 The mean reflectance of the light pipe between the wavelengths  $\lambda$  400 nm to 700 nm was found to be 100%. The specular gloss, according to BS EN ISO 2813 : 2000, was found to be 151 gloss units at 85°.

6.4 A reflector may be inserted in the dome with the reflective side due south, to enhance the level of low light captured.

## 7 Strength and stability



7.1 The systems have an adequate resistance to wind loads calculated in accordance with BS EN 1991-1-4 : 2005 and its UK National Annex.

7.2 The systems are designed to support an imposed load of 1.1 kN. The magnitude of the actual snow load imposed will depend upon a number of factors, such as height above sea level, geographical location, roof arrangement, type and configuration of skylights. Therefore, it is recommended that BS EN 1991-1-3 : 2003 and its UK National Annex are used to calculate the actual snow load when the roof is used in situations where a load greater than 1.1 kN can be expected.

7.3 Details of the connections between the flashing and the roof must be entrusted to a suitably-qualified and experienced individual. Guidance is available from the Certificate holder.

7.4 The polycarbonate dome material has a good resistance to impact from hard bodies, such as hailstones, or impacts owing to vandalism. Tests on typical skylight samples showed that an impact energy of 2.5 J did not cause damage when applied at various points of the skylight dome.

## 8 Weathertightness



8.1 When installed in accordance with the manufacturer's instructions and sections 16 and 17 of this Certificate, the systems will provide adequate resistance to the ingress of precipitation.

8.2 Particular attention must be paid to the correct fitting of all components and to the detailing of sealants and roofing materials.

## 9 Behaviour in relation to fire



9.1 The polycarbonate dome used in the rooflights is classified as Tp(a) rigid and the polycarbonate diffuser is classified as Tp(b) and, in Scotland, Tp(b) semi-rigid in accordance with the national Building Regulations.

9.2 The powder-coated galvanized steel/aluminium roof flashing materials and aluminium rigid light tube material are non-combustible.

## 10 Thermal properties



The design U values detailed in the documents supporting the national Building Regulations should be adjusted by  $+0.5 \text{ W}\cdot\text{m}^{-2}\cdot\text{K}^{-1}$  in accordance with BRE Report BR 443 : 2006 and then compared with the U values given in Table 4. The systems' U values and areas given in Table 4 may be used in SAP or SBEM.

Table 4 System U values and temperature factors<sup>(1)</sup>

Product code	Diffuser area $A_{\text{diffuser}}$ ( $\text{m}^2$ )	Without tube insulation		With tube insulation <sup>(2)</sup>	
		$U_{\text{diffuser}}$ ( $\text{W}\cdot\text{m}^{-2}\cdot\text{K}^{-1}$ )	Temperature factor, $f_{\text{Rsi}}$	$U_{\text{diffuser}}$ ( $\text{W}\cdot\text{m}^{-2}\cdot\text{K}^{-1}$ )	Temperature factor, $f_{\text{Rsi}}$
160DS	0.08	2.1	0.72	1.9	0.75
290DS	0.14	2.2	0.71	2.0	0.74

(1) Tubes extending through unheated roof space.

(2) 25 mm mineral wool tube wrap.

## 11 Condensation risk



11.1 Thermal modelling of the systems in accordance with BS EN ISO 10211 : 2007 indicates the temperature factors shown in Table 4 of this Certificate.

11.2 The risk of condensation forming on an internal surface of the diffuser is dependent on its temperature and the temperature and humidity of the adjacent air. The minimum temperature factor required to avoid surface condensation is dependent on the building type and external temperature for the location, and can be calculated for a particular situation in accordance with BS EN ISO 13788 : 2012. Alternatively, default critical temperature factors for limiting the risk of surface condensation values can be obtained from BRE Information Paper IP 1/06.

11.3 Where the tube passes through an unheated space, it should be sheathed with insulation having a thermal resistance of at least  $0.6 \text{ m}^2\cdot\text{K}\cdot\text{W}^{-1}$ <sup>(1)</sup>.

(1) BRE Report BR 262 : 2002.



11.4 The risk will be minimal when the system's temperature factor exceeds the calculated or critical temperature factors ( $f_{\text{CRsi}}$ ) for the relevant building type. Where the temperature factors in Table 4 are less than the critical temperature factors ( $f_{\text{CRsi}}$ ) for the relevant building type, there is a risk of surface condensation forming. However, limited intermittent condensation, appearing initially on the diffuser, should not be detrimental to the system. By way of comparison, temperature factors for typical PVC-U windows are between 0.50 and 0.65.

11.5 In all cases, the risk of surface condensation can be reduced by limiting activities which produce large amounts of moisture and by providing means for adequate ventilation.

## 12 Safety



12.1 The external surface of the dome cannot be cleaned from inside the building.

12.2 When selecting means of access during the period of installation or maintenance, for example use of scaffolding, the safety of the operatives, occupants and passers-by should be considered.

12.3 If the system is located on a roof which is generally accessible to the public, provision must be made to prevent people falling onto the glazed part (eg guard rails). If, as the result of an accidental fall, contact is made with the polycarbonate dome, the material shows good resistance to impact.

## 13 Maintenance



13.1 If damage occurs, the systems can be re-glazed and the fixings replaced.

13.2 Cleaning of the diffuser or dome should be carried out using water containing household non-abrasive neutral detergent. To avoid scratching the surface, only soft cloths should be used when cleaning.

13.3 The seal applied to the outer edge of the flashing and to all flashing screw heads may need to be replaced within the life of the systems.

## 14 Durability



14.1 The systems will continue to function effectively for a period of at least 10 years.

14.2 Some slight change in colour of the polycarbonate dome will occur in service. However, the change will be even across the dome and will not significantly decrease properties, although light transmittance may be slightly affected.





14.3 Fixings, as described in this Certificate, may need to be replaced within the life of the light tube, particularly when exposed to aggressive environments, such as coastal or industrial locations.

## 15 Reuse and recyclability

The product comprises polycarbonate, galvanized steel and aluminium, each of which can be recycled.

## Installation

### 16 General

Installation of the systems should be carried out in accordance with the Certificate holder's installation instructions.

### 17 Procedure

17.1 A minimum clearance is needed between joists of 275 mm for the Solatube 160DS and 375 mm for the Solatube 290DS in order to install the ceiling diffuser. The location should be chosen so as to provide the straightest route from ceiling diffuser to dome.

17.2 The roof flashing can be positioned either vertically above the diffuser position or to an angle of up to 30° from the vertical. The two angle adaptors can be rotated in any direction to achieve this (see Figure 4).

17.3 A circular hole is cut into the ceiling of the appropriate size and the bottom tube assembly is inserted up into the ceiling. If the installation is not vertical, the angle adaptor is rotated to point towards the roof flashing location. Two of the twist-lock fastening clamps in the assembly are rotated and tightened to temporarily attach the tube assembly to the ceiling (see Figure 5).

17.4 The installation of the roof flashing depends upon the roof type.

Figure 4 Aligning top and bottom tube assemblies

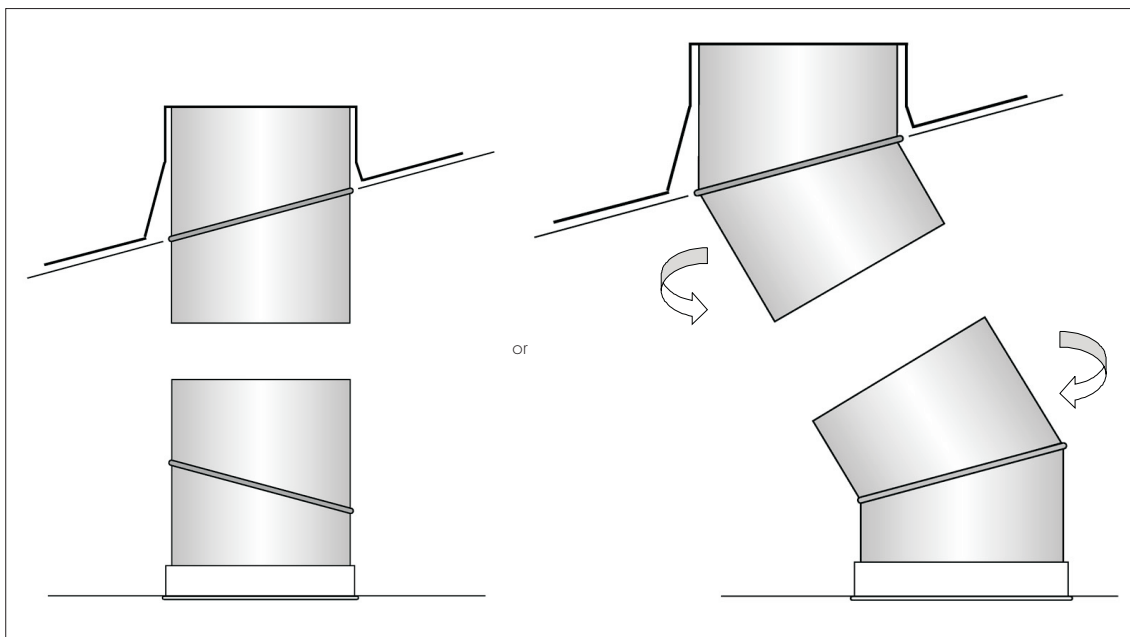
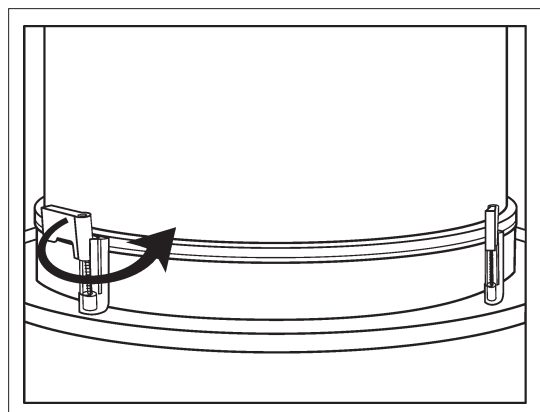

Figure 5 Installation of bottom tube assembly



## Flat roof flashing

- the centre point above the hole cut in the ceiling is located and marked with a nail or screw. The area where the flashing will be located is cleared away thoroughly, ensuring that the surface under the flashing and 75 mm beyond the edge is smooth, level, clean and dry
- a series of eight 5 mm diameter holes are drilled around the edge of the flashing base between, and in addition to, the eight existing holes
- after marking the points of the holes and the outer edges of the flashing, cuts are made through the roof deck 20 mm inside the inner marked line
- sealant is applied onto the outer edge of the flashing and around the hole in the roof and the flashing lowered into position. The flashing is fastened to the roof using 50 mm flashing screws, taking care not to overtighten (see Figure 6). Sealant is finally applied to the outer edge of the flashing and to all flashing screw heads.

## Slate and plain tile flashing

- an area of roof tiles is removed, enough to allow the top and aperture of the flashing to be placed onto the roof battens, leaving sufficient tiles at the bottom edge to allow the flashing to overlap sufficiently onto the tiles below
- any obstructing battens are cut if necessary and the roof felt is cut through in a star shape so the felt can be folded upwards and back on itself. The flashing is placed over the hole and the tube of the top tube assembly temporarily inserted and angled towards the bottom tube assembly in the ceiling
- the top of the flashing is secured with flashing screws to the appropriate batten and sealant applied to the top of each fixing screw head. Sealant is also applied to the side sections of the flashing onto which the tiles will be re-laid
- sealant is applied to the bottom edge of the flashing, between the flashing and the tiles underneath, and across the top edge of the flashing. Roof tiles are re-laid and fixed to the sides and top of the flashing, ensuring that a 40 mm gap exists behind the flashing upstand to allow the top tube assembly, dome ring and dome to be inserted into the flashing upstand (see Figure 7).

Figure 6 Flat roof flashing installation

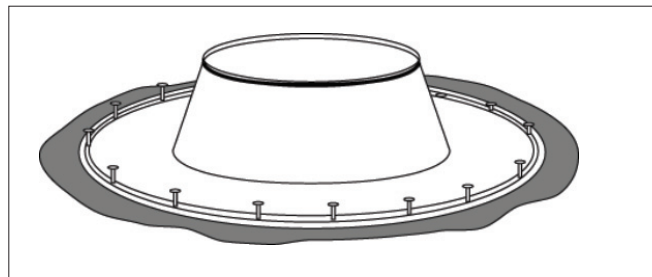
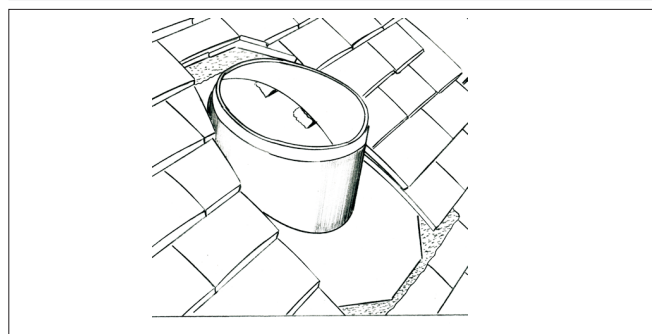

Figure 7 Slate and tile flashing installation



## Interlocking tile flashing

- an area of roof tiles is removed, enough to allow the top and aperture of the flashing to be placed onto the roof battens, leaving sufficient tiles at the bottom edge to allow the flashing to overlap sufficiently onto the tiles below
- any obstructing battens are cut if necessary (see section 4.4) and the roof felt is cut through in a star shape so that the felt can be folded upwards and back on itself. The flashing is placed over the hole, and the tube of the top tube assembly is temporarily inserted and angled towards the bottom tube assembly in the ceiling
- the top of the flashing is secured with flashing screws to the appropriate batten and hand-pressure applied to the bottom edge of the flashing over the shape of the tiles beneath it. The left and right edges of the flashing are turned up to ensure that water does not ingress (see Figure 8)
- aluminium 'L' brackets are carefully fitted to the tiles to secure the lower end of the flashing. The backing of Solafom strip is removed and the strip is adhered to the flashing surface, placing it so that it is covered and compressed when the removed tiles have been replaced. Tiles are re-laid ensuring that a 40 mm gap is left behind the upstand to allow the top tube assembly, dome ring and dome to be inserted into the flashing upstand. Finally, the top of the flashing is moulded by hand as necessary to fit the underside shape of the tiles (see Figure 9).

Figure 8 Securing the interlocking tile flashing

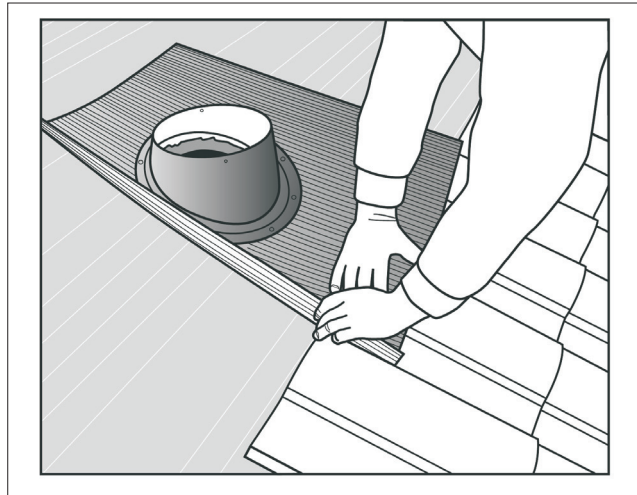
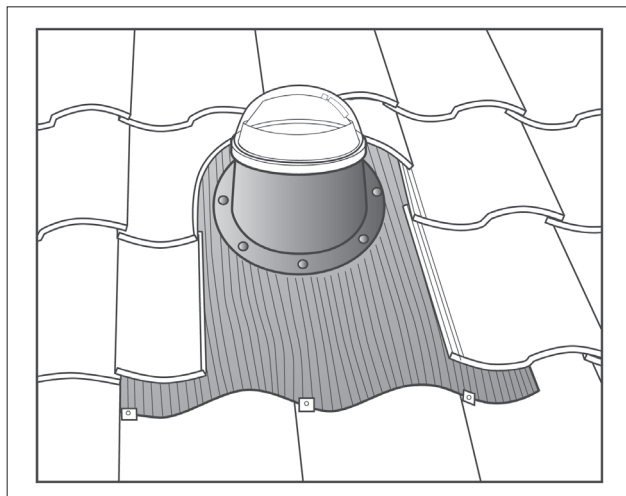

Figure 9 Interlocking tile flashing installation



17.5 The top tube assembly is inserted into the roof flashing from the outside. Metal roof flashings have pre-drilled holes. The dome ring fixing holes align with these holes and dome screws are screwed through to the flashing to hold the top tube assembly temporarily in place.

17.6 Angle adaptors are rotated so that the top tube assembly points towards the bottom tube assembly in the ceiling. The lengths 'L1' and 'L2' (see Figure 10) should be equal to ensure alignment<sup>(1)</sup>.

(1) For flat/vaulted ceiling applications where no extension tubes are required, the bottom tube assembly will be fitted up inside the top tube assembly.

17.7 The top tube assembly is unscrewed and the angle adaptor joint and tube seams are taped with the foil tape supplied by the Certificate holder.

17.8 The protective lining film is removed from the inside of the tube and the top tube assembly replaced back into the roof flashing, again aligning it with the bottom tube assembly. The assembly is securely fastened to the flashing using the dome screws.

17.9 A LightTracker reflector is placed in the north side of the dome, with the reflective side facing due south. The holes in the reflector are aligned with moulded tabs inside the dome and snapped into place. The protective film is removed from the reflector.

Figure 10 Showing equal alignment of top and bottom tube assemblies

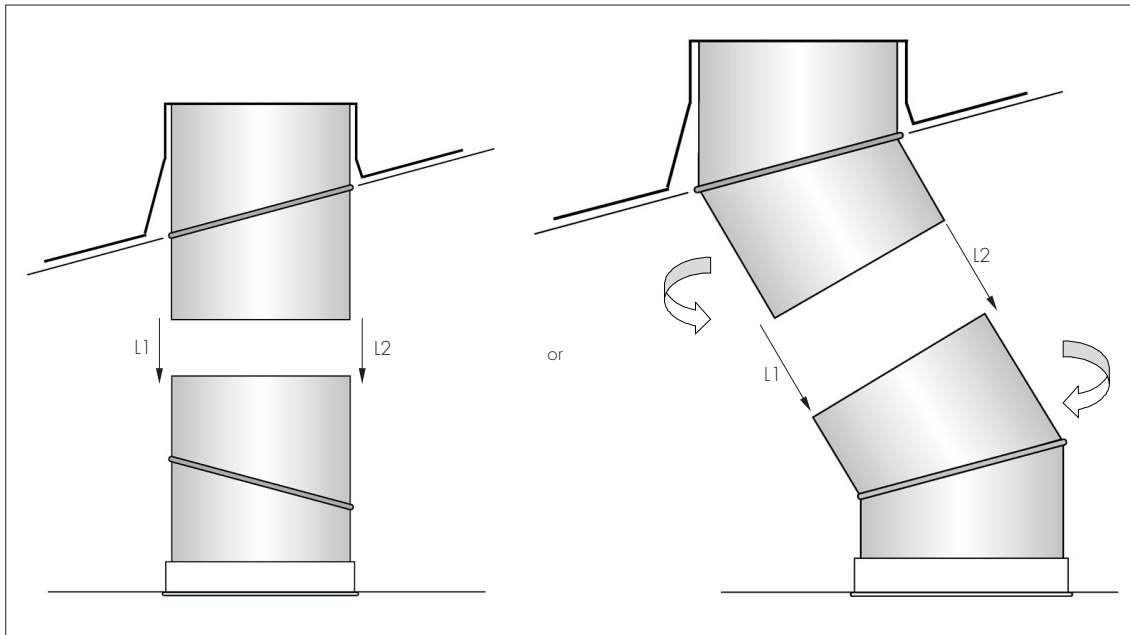

17.10 Ensuring that the LightTracker reflector in the dome is facing due south, the four tabs on the dome base are aligned with the snaps on the dome ring and firmly pressed down to click into place.

17.11 An expansion joint seal is applied, 25 mm from the top edge of the bottom tube assembly for short installations without extension tubes, or 25 mm from the top edge of the uppermost extension tube for longer installations.

17.12 Final adjustments are made to align the bottom tube assembly with any extension tubes to the upper ceiling assembly, and then all four twist-lock fastening clamps are locked into place to fasten securely into the ceiling. The protective film is removed from the inside of the bottom tube assembly and the extension tubes.

17.13 The ceiling diffuser is fitted to the opening of the bottom tube assembly, applying firm upward pressure until it snap fits into position. The diffuser is held in place by an interference fit in the bottom tube assembly and can be removed if required by pulling down on the outside of the white dress ring.

## Technical Investigations

### 18 Tests

Tests were carried out to determine:

- watertightness
- effect of wind loads
- effect of snow loads
- effect of impact
- light transmission and haze
- loss of light owing to bending
- suitability of materials
- reflectance
- specular gloss.

### 19 Investigations

19.1 The manufacturing process was evaluated, including the methods adopted for quality control, and details were obtained relating to the quality and composition of the materials used.

19.2 A site visit was conducted to establish the systems' performance and durability in service.

19.3 An examination was made of existing data in relation to performance in fire.

19.4 Thermal performance and temperature factors of the systems were assessed using thermal simulation.

## Bibliography

- BS EN 1991-1-3 : 2003 *Eurocode 1 : Actions on structures — General actions — Snow loads*  
NA to BS EN 1991-1-3 : 2003 UK National Annex to *Eurocode 1 : Actions on structures — General actions — Snow loads*
- BS EN 1991-1-4 : 2005 *Eurocode 1 : Actions on structures — General actions — Wind actions*  
NA to BS EN 1991-1-4 : 2005 UK National Annex to *Eurocode 1 : Actions on structures — General actions — Wind actions*
- BS EN ISO 2813 : 2000 *Paints and varnishes — Determination of specular gloss of non-metallic paint films at 20 degrees and 85 degrees*
- BS EN ISO 10211 : 2007 *Thermal bridges in building construction — Heat flows and surface temperatures — Detailed calculations*
- ASTM D 1003 : 2000 *Test Method for Haze and Luminous Transmittance of Transparent Plastics*
- BS EN ISO 13788 : 2012 *Hygrothermal performance of building components and building elements — Internal surface temperature to avoid critical surface humidity and interstitial condensation — Calculation methods*
- BRE Information Paper IP 1/06 *Assessing the effects of thermal bridging at junctions and around openings*
- BRE Report (BR 262 : 2002) *Thermal insulation : avoiding risks*
- BRE Report (BR 443 : 2006) *Conventions for U-value calculations*

## 20 Conditions

20.1 This Certificate:

- relates only to the product/system that is named and described on the front page
- is issued only to the company, firm, organisation or person named on the front page — no other company, firm, organisation or person may hold or claim that this Certificate has been issued to them
- is valid only within the UK
- has to be read, considered and used as a whole document — it may be misleading and will be incomplete to be selective
- is copyright of the BBA
- is subject to English Law.

20.2 Publications, documents, specifications, legislation, regulations, standards and the like referenced in this Certificate are those that were current and/or deemed relevant by the BBA at the date of issue or reissue of this Certificate.

20.3 This Certificate will remain valid for an unlimited period provided that the product/system and its manufacture and/or fabrication, including all related and relevant parts and processes thereof:

- are maintained at or above the levels which have been assessed and found to be satisfactory by the BBA
- continue to be checked as and when deemed appropriate by the BBA under arrangements that it will determine
- are reviewed by the BBA as and when it considers appropriate.

20.4 The BBA has used due skill, care and diligence in preparing this Certificate, but no warranty is provided.

20.5 In issuing this Certificate, the BBA is not responsible and is excluded from any liability to any company, firm, organisation or person, for any matters arising directly or indirectly from:

- the presence or absence of any patent, intellectual property or similar rights subsisting in the product/system or any other product/system
- the right of the Certificate holder to manufacture, supply, install, maintain or market the product/system
- actual installations of the product/system, including their nature, design, methods, performance, workmanship and maintenance
- any works and constructions in which the product/system is installed, including their nature, design, methods, performance, workmanship and maintenance
- any loss or damage, including personal injury, howsoever caused by the product/system, including its manufacture, supply, installation, use, maintenance and removal
- any claims by the manufacturer relating to CE marking.

20.6 Any information relating to the manufacture, supply, installation, use, maintenance and removal of this product/system which is contained or referred to in this Certificate is the minimum required to be met when the product/system is manufactured, supplied, installed, used, maintained and removed. It does not purport in any way to restate the requirements of the Health and Safety at Work etc. Act 1974, or of any other statutory, common law or other duty which may exist at the date of issue or reissue of this Certificate; nor is conformity with such information to be taken as satisfying the requirements of the 1974 Act or of any statutory, common law or other duty of care.